

STRAIGHT-SIDED REFRACTORS

Models 220, 225, 230, 235 and 237



Model 220 Type V

Description

These 9.5" diameter refractors are designed for use in residential areas, parks, decorative post-top, commercial and industrial applications. Open bottom refractors provide relamping and maintenance ease, while closed bottom refractors provide additional protection for the light source. Models 220 (closed bottom) and 225 (open bottom) are high impact polycarbonate refractors for use in areas that may be subject to breakage. Models 230 (closed bottom) and 235 (open bottom) are UV stabilized acrylic refractors for high efficiency operation in general application usage. Model 237 (open bottom) is a UV stabilized lightweight acrylic refractor for economical, high efficiency operation in general application usage.

Lamp Data

This refractor series is widely used with 35W - 150W, medium based HID lamps. When using Models 225 and 235 (open bottom versions) in exterior applications, 175W HID lamps are the maximum wattage we recommend using.

Thermal tests should be conducted on each luminaire design with the proposed light source in its selected position to confirm lamp size and suitability, and to predict service life of the refractor.

Ordering Information

Please call 800-228-5275 231-547-6584 for price and delivery. Typical lead time is four to six weeks.

Service Life

The service life of acrylic refractors is virtually unlimited when used within the recommended temperature limit. Polycarbonate refractors are subject to yellowing especially when used with high ultraviolet output light sources; this effect is enhanced at high temperatures.

Notice

A.L.P. Lighting Components, Inc. assumes no responsibility for suitability of luminaires and applications. The use of our molded products at excessive temperatures with high UV output light sources will cause degradation of the material. Information regarding the use of lenses and refractors with Metal Halide lamps can be found in the Products/Technical Resources section of our web site at www.alplighting.com.

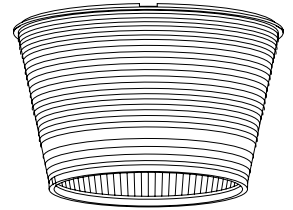

Models 220, 225, 230, 235 and 237

5.70" high
9.5" diameter

COMMERCIAL, INDUSTRIAL,
ROADWAY, STREET AND
DECORATIVE LIGHTING
APPLICATIONS

Model 235 Type V
Efficiency: 87.18%
IES Classification: Type V, Semi-cutoff
Arc Tube Voltage Rise = 0.3

Materials: Acrylic and polycarbonate



Models 220, 225 230, 235, 237

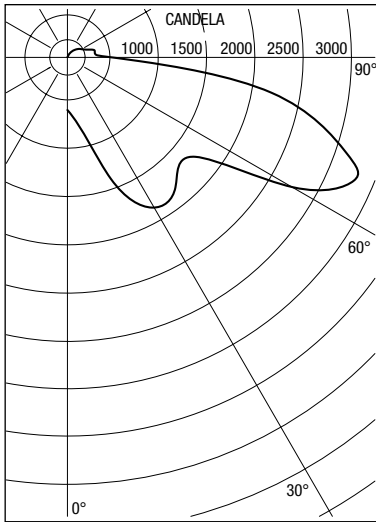

Photometrics

Models 220, 225, 230 and 235 are available in IES Type V symmetrical distribution for general area lighting and IES Type III two-way asymmetrical distributions for parking facilities, off-roadway or area lighting. Model 235 Type III refractor produces a maximum of 9774 candela at 70° vertical, 65° lateral with a 150W clear, medium based, HPS lamp (ITL35512). Model 235 Type V produces 3312 candela at 67.5° vertical with a 100W clear HPS lamp, as shown at left (ITL41894). The vertical angle of maximum candela can be adjusted approximately 6° with movement of the light center position. Individual luminaire performance depends on the lamp center position and the reflector design chosen. Each luminaire design should be individually tested for proper classification. Please visit our web site for additional photometric data.

Report Number: ITL41894
 Total Luminaire Efficiency = 87.18%
 IES Classification: Type V, Semi-cutoff
 Arc Tube Voltage Rise = 0.3

Materials

See the LexaLite brand price list for current part numbers and material offerings. Up-to-date and detailed material specifications can be found in the Products/Technical Resources section of our web site at www.alplighting.com.

UvaLex® is LexaLite's proprietary treatment to retard yellowing in ultraviolet environments and is standard on these polycarbonate refractors.

When using acrylic Models 230, 235 and 237 the surface temperature of the refractor should not exceed 80°C. When using polycarbonate Models 220 and 225, the surface temperature of the Reflector should not exceed 90°C.

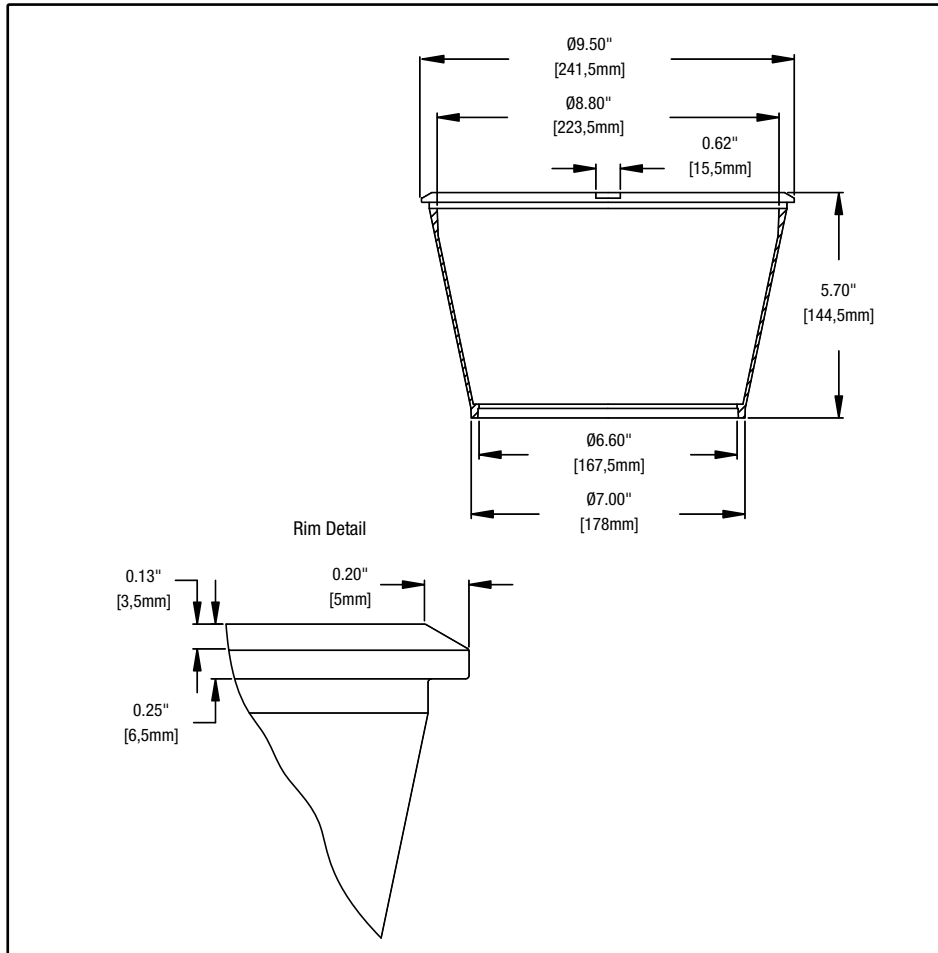

**This drawing is for reference only. Actual part dimensions will vary.
 Customer is urged to review actual samples to confirm fit and function.
 All specifications and dimensions are subject to change without notice.**